

AIRPORT ROAD/HIGHWAY 30 INTERSECTION IMPROVEMENTS

Lexington, Nebraska
Project No. 127-A1-115

PROPOSAL FORM

The City of Lexington will accept proposals until 10:00 AM local time, February 7, 2020 at Lexington City Hall on the Airport Road/Highway 30 Intersection Improvement project. The undersigned, having carefully examined the proposal form, drawings and specifications for the Intersection Improvements for the City of Lexington, have personally reviewed the site conditions for the execution of such work according to the following schedule of approximate quantities as set forth. Work will be completed in accordance with Miller & Associates Specifications, Section 12 – Portland Cement Concrete Pavement. A copy of Section 12 Specifications is available upon request. Work incidental to construction includes but is not limited to mobilization, subgrade preparation, joint sealing, barricades & and other subsidiary work. Borrow material required for construction may be obtained north of the intersection @ 20th Street & Airport Road at no cost to the Contractor. Contractor will be required to submit a traffic control and barricade placement plan as per NDOT Standards. Airport Road shall remain open to traffic during construction. See attached drawing.

<i>Item No.</i>	<i>Description</i>	<i>Quantity</i>	<i>Unit Price</i>	<i>Total Amount</i>
1.	Saw Cut, Remove & Haul Concrete	1	Lump Sum	
2.	Moisture Condition Subgrade and Compact to Project Specifications	1	Lump Sum	
3.	Drill and Install Tie Bars in Existing Slab @ 3' C-C	1	Lump Sum	
4.	Construct 9" Thick Concrete Pavement – Approx. 92 S.Y.	1	Lump Sum	
5	Final Grading and Seeding	1	Lump Sum	

TOTAL PROPOSAL \$ _____

Anticipated Start Date _____

Anticipated Completion Date _____

The City time line to complete the project is before – May 15, 2020.

In submitting this proposal, the Contractor further states that he is complying with, and if awarded a contract, will continue to comply with Fair Labor Standards as defined in 73-104, Reissue Revised Statutes of Nebraska 1943, as amended, in the pursuit of his business and in the execution of the contract on which he is bidding.

Respectfully submitted this ___ day of _____, 2019

[COMPANY NAME] _____

By _____
(Name)

(Title)



NEW CONSTRUCTION

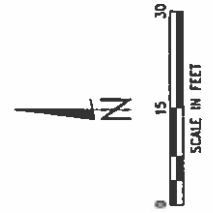

PREPARED BY:
M&A
 MILLER & ASSOCIATES
 CONSULTING ENGINEERS, P.C.
 1111 CENTRAL AVENUE
 KEARNEY, NE 68847



REMOVALS

LEXINGTON, NEBRASKA

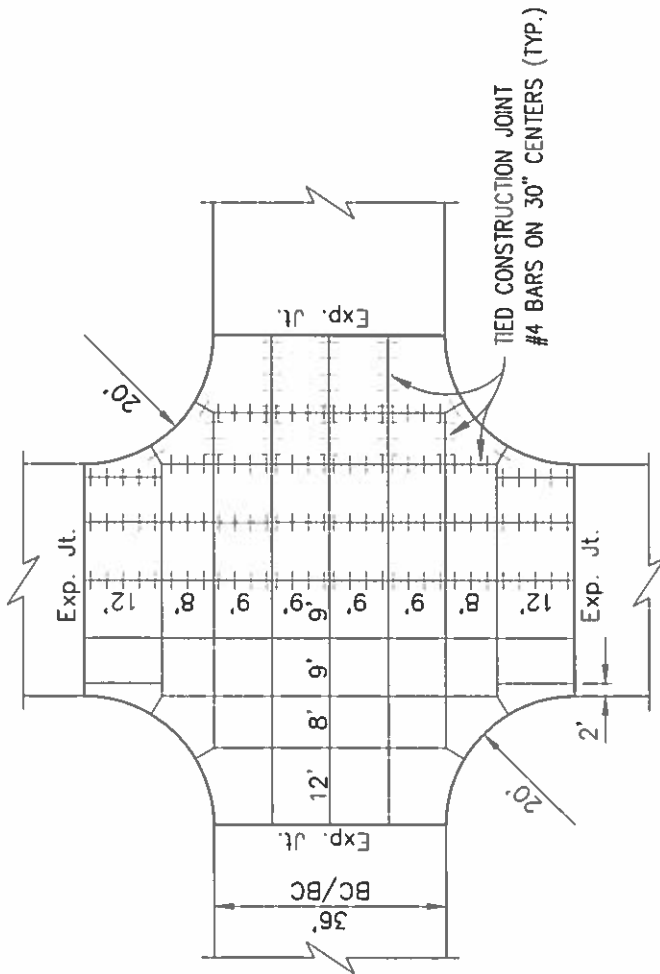

TYPICAL INTERSECTION JOINT PATTERN
NO SCALE

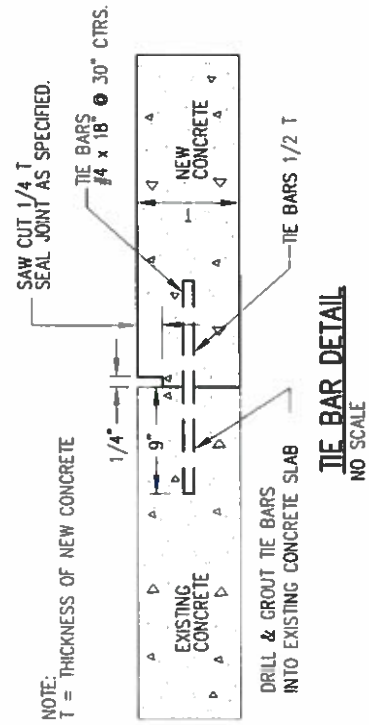

TIE BAR DETAIL
NO SCALE

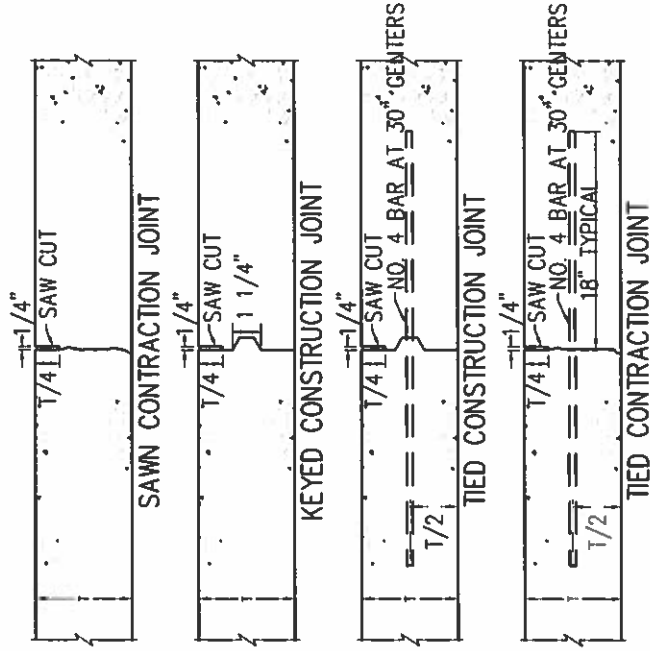

NOTE: SEAL JOINTS AS SPECIFIED.
CONCRETE JOINT DETAIL
NO SCALE

TYPICAL CONCRETE PAVING DETAILS